

NEW PRODUCT

FLANGE SPREADER

■ Model No. **K-SW15TE**

Height: 288 mm
Weight: 7.5 kgs



■ Specifications:

Max. Pressure : 700 bar
Oil Required : 79 cc
Max Output : 14.0 tons / 137.2 kN

■ Spreader Capacity:

- Tip Clearance : 33 mm
- Max. Spread : 81 mm

■ Features:

- Integrated wedge concept: friction-free, smooth, parallel wedge movement eliminates flange damage and spreading arm failure.
- Unique interlocking wedge design: no first step bending and risk of slipping out of joint.
- Requires very small access gap of only 6 mm (.24 in).
- Few moving parts means durability and low maintenance.
- Operated by any hydraulic pump with rated oil pressure of 700 bar (10,000 psi).



■ Accessories:

Safety Block

■ Pump recommendation:



CEP-15SS
Max Pressure : 700 bar
1.2L / min at low pressure
0.3L / min at high pressure



EP-30S
Max Pressure : 700 bar
2.6 L / min at low pressure
0.32 L / min at high pressure



EP-30MS
Max Pressure : 700 bar
Valve Type :
2-way, 2-position Manual Valve
2.6 L / min at low pressure
0.32 L / min at high pressure



EP-76MS
Max Pressure : 700 bar
3.9 L / min at low pressure
0.2 L / min at high pressure



EP-76SS
Max Pressure : 700 bar
3.9 L / min at low pressure
0.2 L / min at high pressure



EP-76SSC
Max Pressure : 700 bar
3.9 L / min at low pressure
0.2 L / min at high pressure

■ Dimensions:

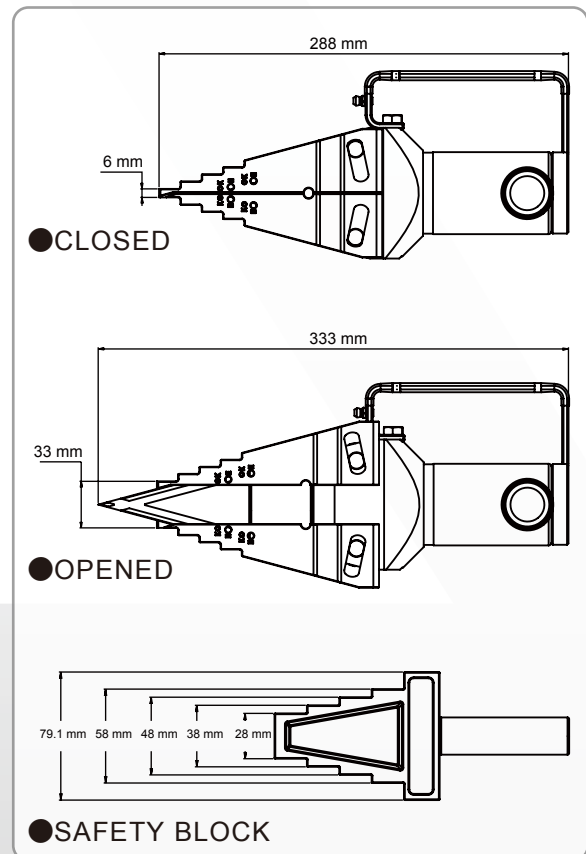

**NEW
PRODUCT**

FLANGE SPREADER

■ Model No. **K-SW9TM**

Height: 283 mm
Weight: 6.0 kgs



■ Specifications:

Max. Pressure : 700 bar
Max Output : 8.0 tons / 78.4 kN

■ Spreader Capacity:

- Tip Clearance : 32 mm
- Max. Spread : 81 mm

■ Features:

- Integrated wedge concept: friction-free, smooth, parallel wedge movement eliminates flange damage and spreading arm failure.
- Unique interlocking wedge design: no first step bending and risk of slipping out of joint.
- Requires very small access gap of only 6 mm (.24 in).
- Few moving parts means durability and low maintenance.



■ Accessories:

Safety Block
Wrench (22 mm)



■ Dimensions:

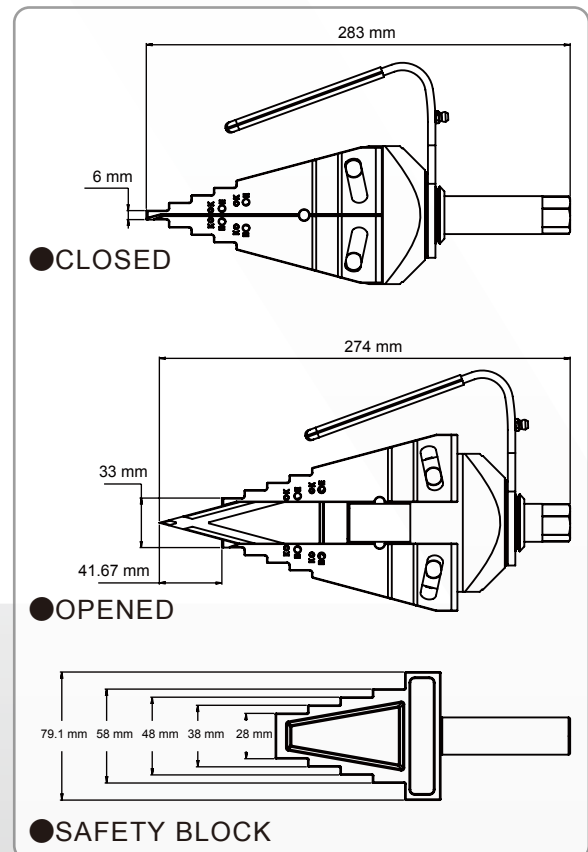

**NEW
PRODUCT**

FLANGE SPREADER

■ Model No. **DFS-8**

Height: 445 mm
Weight: 9.0 kgs



■ Specifications:

Max. Pressure : 700 bar
Oil Required : 79 cc
Max Output : 14.0 tons / 137.2 kN

■ Spreader Capacity:

- Tip Clearance : 32 mm
- Max. Spread : 81 mm



■ Features:

- Integrated wedge concept: friction-free, smooth, parallel wedge movement eliminates flange damage and spreading arm failure.
- Unique interlocking wedge design: no first step bending and risk of slipping out of joint.
- Requires very small access gap of only 6 mm (.24 in).
- Few moving parts means durability and low maintenance.

■ Accessories:

Safety Block

■ Dimensions:

