

SIPROTEC 5 Devices and Fields of Application

Distance Protection – SIPROTEC 7SA87

Description

The SIPROTEC 7SA87 distance protection has specifically been designed for the protection of lines. Due to its modular structure and flexibility and the powerful engineering tool DIGSI 5, SIPROTEC 7SA87 offers future-oriented system solutions with high investment security and low operating costs.

Main function	Distance protection
Tripping	1-pole and 3-pole, minimum tripping time: 9 ms
Inputs and outputs	12 predefined standard variants with 4/4 or 8/8 current/voltage transformers, 5 to 31 binary inputs, 8 to 46 binary outputs
Hardware flexibility	Flexibly adjustable I/O quantity structure within the scope of the SIPROTEC 5 modular system
Housing width	1/3 × 19" to 2/1 × 19"

Functions

DIGSI 5 permits all functions to be configured and combined as required.

- Minimum tripping time: 9 ms
- 6 independent measuring loops (6-system distance protection)
- Several distance-protection functions can be selected: Classic, reactance method (RMD), impedance protection for transformers
- Directional backup protection and various additional functions
- Recognition of static, intermittent and transient ground faults (fleeting contact function) in arc-suppression-coil-ground and isolated power systems
- Adaptive power-swing blocking, out-of-step protection
- Detection of current-transformer saturation for fast tripping with high accuracy
- Arc protection
- Power protection, configurable as active or reactive power protection
- Reactive power-undervoltage protection (QU protection)
- Detection of current and voltage signals up to the 50th harmonic with high accuracy for selected protection functions (such as thermal overload protection) and operational measured values
- 3-pole automatic reclosing function
- Control, synchrocheck and switchgear interlocking protection
- Graphical logic editor to create powerful automation functions in the device
- Single line representation in small or large display
- Integrated electrical Ethernet RJ45 for DIGSI 5 and IEC 61850 (reporting and GOOSE)
- Up to 4 optional pluggable communication modules, usable for different and redundant protocols (IEC 61850, IEC 60870-5-103, IEC 60870-5-104, Modbus TCP, DNP3 (serial and TCP))



[SIP5_GD_W3, 1, --]

Figure 2.6/6 SIPROTEC 7SA87

- Serial protection data communication via optical fibers, two-wire connections and communication networks (IEEE C37.94, and others), including automatic switchover between ring and chain topology
- Redundancy protocols PRP and HSR
- Cyber security in accordance with NERC CIP and BDWE White-paper requirements
- Phasor measurement unit (PMU) for synchrophasor measured values and IEEE C37.118 protocol
- Time synchronization using IEEE 1588
- Powerful fault recording (buffer for a max. record time of 80 s at 8 kHz or 320 s at 2 kHz)
- Auxiliary functions for simple tests and commissioning
- Flexibly adjustable I/O quantity structure within the scope of the SIPROTEC 5 modular system

Applications

- Detection and selective 1-pole and 3-pole tripping of short circuits in electrical equipment of star networks, lines with infeed at one or two ends, parallel lines and open or closed ring systems of all voltage levels
- Detection of ground faults in isolated or arc-suppression-coil-ground power systems in star, ring, or meshed arrangement
- Protection data communication over different distances and physical media, such as optical fiber, two-wire connections, and communication networks
- Backup protection for differential protection devices of all kind for lines, transformers, generators, motors, and busbars
- Phasor measurement unit (PMU).

Application templates

Application templates are available in DIGSI for standard applications. They comprise all basic configurations and default settings.

SIPROTEC 5 Devices and Fields of Application

The following application templates are available:

- Basic distance protection
- Distance protection reactance method (RMD) for overhead line for grounded systems, with AR
- Distance protection reactance method (RMD) for overhead line for grounded systems, with AR for applications with breaker-and-a-half schemes

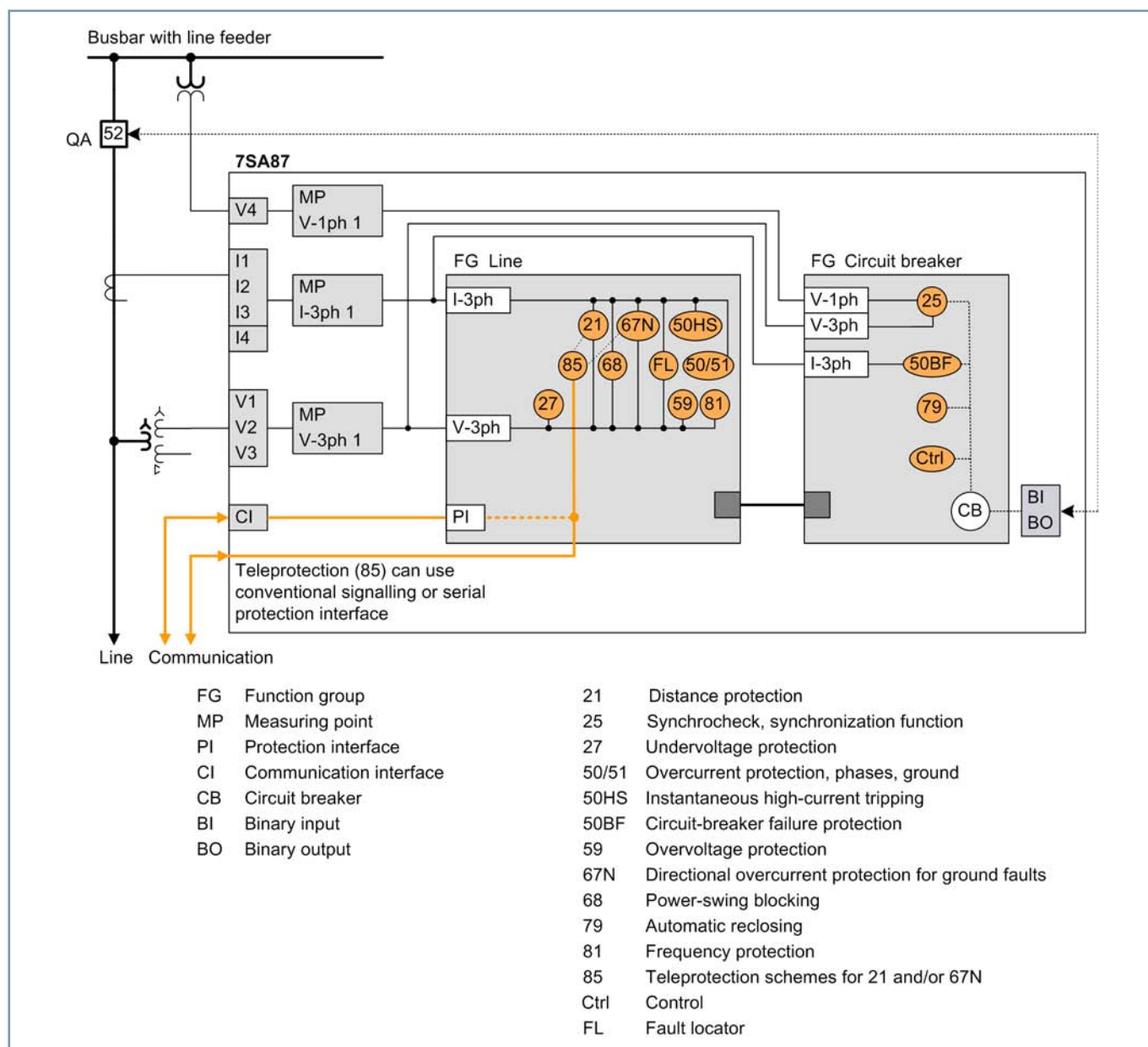

[dw_7SA87_Ltg, 1, en_US]

Figure 2.6/7 Application example: Distance protection for overhead line

SIPROTEC 5 Devices and Fields of Application

Distance Protection – SIPROTEC 7SA87

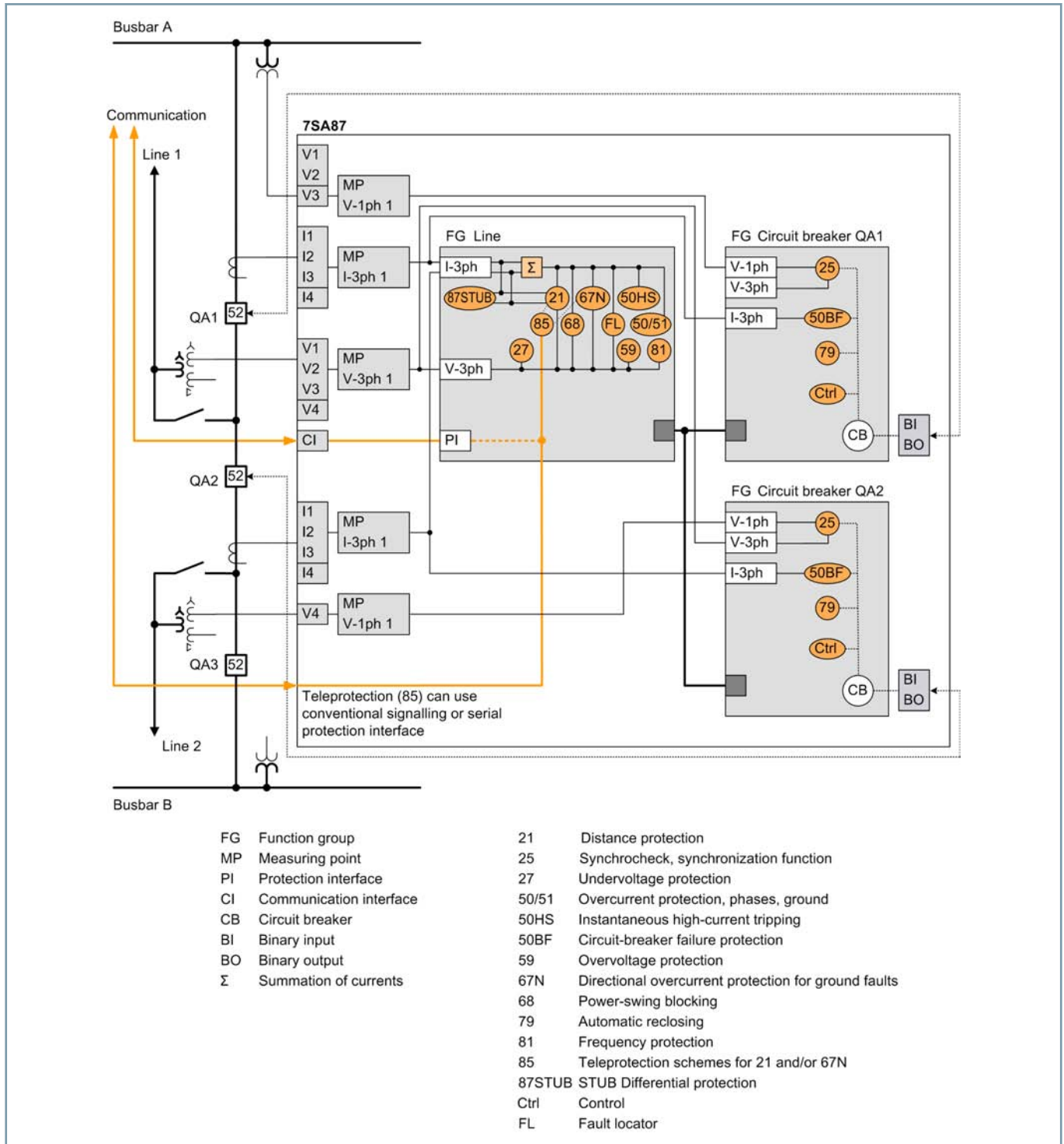

Figure 2.6/8 Application example: Distance protection for overhead line with breaker-and-a-half scheme

SIPROTEC 5 Devices and Fields of Application

Distance Protection – SIPROTEC 7SA87

Functions, application templates

ANSI	Functions	Abbr.	Available	Template		
				1	2	3
	Protection functions for 3-pole tripping	3-pole	■	■	■	■
	Protection functions for 1-pole tripping	1-pole	■	■	■	■
	Hardware quantity structure expandable	I/O	■	■	■	■
21/21N	Distance protection	$Z<$, $V</I>/\angle(V,I)$	■	■	■	■
21T	Impedance protection for transformers	$Z<$	■			
25	Synchrocheck, synchronizing function	Sync	■		■	■
27	Undervoltage protection: "3-phase" or "pos.seq. V1" or "universal Vx"	$V<$	■			
	Undervoltage-controlled reactive power protection	$Q>/V<$	■			
32, 37	Power protection active/reactive power	$P<>$, $Q<>$	■			
37	Undercurrent	$I<$	■			
38	Temperature Supervision	$\theta>$	■			
46	Negative sequence overcurrent protection with direction	$I2>$, $\angle(V2,I2)$	■			
47	Overvoltage protection, negative-sequence system	$V2>$	■			
49	Thermal overload protection	θ , I^2t	■		■	■
50/51 TD	Overcurrent protection, phases	$I>$	■	■	■	■
50N/ 51N TD	Overcurrent protection, ground	$IN>$	■	■	■	■
50HS	High speed instantaneous overcurrent protection	$I>>>$	■	■	■	■
	Instantaneous tripping at switch onto fault	SOTF	■			
50N/ 51N TD	Overcurrent protection, 1-phase	$IN>$	■			
50Ns/ 51Ns	Sensitive ground-current protection for systems with resonant or isolated neutral	$INs>$	■			
	Intermittent ground fault protection	$lie>$	■			
50BF	Circuit-breaker failure protection, 1-/3-pole	CBFP	■		■	■
51V	Voltage dependent overcurrent protection	$t=f(I,V)$	■			
59, 59N	Overvoltage protection: "3-phase" or "zero seq. V0" or "pos.seq. V1" or "universal Vx"	$V>$	■			
67	Directional overcurrent protection, phases	$I>$, $\angle(V,I)$	■			
67N	Directional overcurrent protection for ground faults in grounded systems	$IN>$, $\angle(V,I)$	■		■	■
67Ns	Dir. sensitive ground-fault detection for systems with resonant or isolated neutral incl. a) $3I0>$, b) $V0>$, c) Cos/SinPhi , d) Transient fct., e) $\text{Phi}(V,I)$, f) admittance		■			
	Directional intermittent ground fault protection	$lie\ dir>$	■			
68	Power-swing blocking	$\Delta Z/\Delta t$	■		■	■
74TC	Trip circuit supervision	TCS	■			
78	Out-of-step protection	$\Delta Z/\Delta t$	■			
79	Automatic reclosing, 1-/3-pole	AR	■		■	■
81	Frequency protection: "f>" or "f<" or "df/dt"	$f>$, $f<$; $df/dt>$, $f<$	■			
85/21	Teleprotection for distance protection		■	■	■	■
85/27	Weak or no infeed: Echo and Tripping	WI	■	■	■	■
85/67N	Teleprotection for directional ground fault protection		■	■	■	■
86	Lockout		■			
87N T	Restricted ground-fault protection	ΔIN	■			
87 STUB	STUB Differential protection (for one-and-half circuit-breaker applications)		■			■

2.6

SIPROTEC 5 Devices and Fields of Application

Distance Protection – SIPROTEC 7SA87

ANSI	Functions	Abbr.	Available	Template		
				1	2	3
90V	Automatic voltage control for 2 winding transformer		■			
90V	Automatic voltage control for 3 winding transformer		■			
90V	Automatic voltage control for grid coupling transformer		■			
FL	Fault locator, single-ended measurement	FL-one	■	■	■	■
PMU	Synchrophasor measurement (1 PMU can be used for max. 8 voltages and 8 currents)	PMU	■			
AFD	Arc-protection (only with plug-in module ARC-CD-3FO)		■			
	Measured values, standard		■	■	■	■
	Measured values, extended: Min, Max, Avg		■			
	Switching statistic counters		■	■	■	■
	Circuit breaker wear monitoring	$\Sigma I_x, I^2t, 2P$	■			
	CFC (Standard, Control)		■	■	■	■
	CFC arithmetic		■			
	Switching sequences function		■			
	Inrush current detection		■			
	External trip initiation		■	■	■	■
	Control		■	■	■	■
	Fault recording of analog and binary signals		■	■	■	■
	Monitoring and supervision		■	■	■	■
	Protection interface, serial		■	■	■	■
	Circuit Breaker		■	■	■	■
	Disconnecter		■			■
	Region France: Overload protection for lines and cables 'PSL-PSC'		■			
	Region France: Overcurrent protection 'MAXI-L'		■			
	Region France: Net decoupling protection 'PDA'		■			
	Region France: Overload protection for transformers		■			
Function-points class:				0	225	400
The configuration and function points for your application can be ascertained in the SIPROTEC 5 order configurator under: www.siemens.com/siprotec						

Table 2.6/3 SIPROTEC 7SA87 - Functions and application templates

- 1 DIS Basic
- 2 DIS RMD overhead line, solid grounded neutral point
- 3 DIS RMD overhead line, solid grounded neutral point, 1.5 CB