

SIPROTEC 5 Devices and Fields of Application

Transformer Differential Protection – SIPROTEC 7UT86

Description

The SIPROTEC 7UT86 transformer differential protection has been designed specifically for the protection of three-winding transformers (3 sides). It is the main protection for the transformer and contains many other protection and monitoring functions. The additional protection functions can also be used as backup protection for protected downstream objects (such as cables, line). In this process, you are also supported by the modular expandability of the hardware. The device supports all SIPROTEC 5 system properties. It enables future-oriented system solutions with high investment security and low operating costs. With its modular structure, flexibility and the powerful DIGSI 5 engineering tool, SIPROTEC 7UT86 offers future-oriented system solutions with high investment security and low operating costs.

Main function	1 differential protection function (standard) with additional stabilization; up to 3 ground fault differential protection functions For auto transformer applications, two differential protection functions can be processed in an Auto transformer function group.
Usable measuring points	6 x 3-phase current measuring points, 4 x 1-phase current measuring points, 4 x 3-phase voltage measuring points; expandable to 4 sides
Inputs and outputs	2 predefined standard variants with 12 current transformers 4 voltage transformers, 11 to 23 binary inputs, 18 to 34 binary outputs
Hardware flexibility	Flexibly adjustable and expandable I/O quantity structure within the scope of the SIPROTEC 5 modular system
Housing width	1/2 x 19" - 2/1 x 19"



[SIP5_GD_LEDSS_W3_1, --,--]

Figure 2.11/9 SIPROTEC 7UT86 transformer differential protection (1/2 device = standard variant P1)

2.11

Benefits

- Safety due to powerful protection functions
- Data security and transparency over the entire lifecycle of the plant save time and money
- Purposeful and simple operation of the devices and software thanks to user-friendly design
- Increased reliability and quality of the engineering process
- Consistent implementation of high safety and security mechanisms
- Powerful communication components ensure safe and effective solutions
- Full compatibility between IEC 61850 Editions 1 and 2
- Highly available Ethernet communication due to integrated Ethernet redundancy protocols PRP and HSR

Functions

DIGSI 5 permits all functions to be configured and combined as required.

- Transformer differential protection for three-winding transformers with versatile, additional protection functions; expandable to four-winding transformers
- Transformer differential protection for phase-angle regulating transformers of the single core type and special transformers
- Universal usability of the permissible measuring points

- Applicable from average up to extra-high voltage
- Protection of standard power transformers, auto transformers and motors
- Typical properties of a transformer differential protection such as flexible adaptation to the transformer vector group, control of inrush and overexcitation processes, safe behavior in the case of current-transformer saturation with different degrees of saturation
- Adaptive adaptation of the operate curve to the transformer tap position
- Increased sensitivity with near-neutral-point ground faults through a separate ground fault differential protection
- Additional current and voltage inputs can be supplements for standard protection functions, such as overcurrent, voltage frequency, etc.
- Graphical logic editor to create powerful automation functions in the device
- Arc protection
- Voltage controller function ANSI 90V for two-winding transformers, three-winding transformers and grid coupling transformers
- Up to 4 pluggable communication modules, usable for different and redundant protocols (IEC 61850, IEC 60870-5-103, IEC 60870-5-104, DNP3 (serial and TCP), Modbus TCP)
- Redundancy protocols PRP and HSR
- Cyber security in accordance with NERC CIP and BDWE White-paper requirements
- Secure serial protection data communication, also over great distances and all available physical media (fiber-optic cable, 2-wire connections and communication networks)
- Capturing operational measured variables and protection function measured values to evaluate the plant state, to support commissioning, and to analyze faults

- Phasor measurement unit (PMU) for synchrophasor measured values and IEEE C37.118 protocol
- Powerful fault recording (buffer for a max. record time of 80 s at 8 kHz or 320 s at 2 kHz)
- Auxiliary functions for simple tests and commissioning
- Flexibly adjustable I/O quantity structure within the scope of the SIPROTEC 5 modular system

Applications

Application templates are available in DIGSI 5 for standard applications. They contain basic configurations and default settings. These can be used directly or as a template for application-related adaptation. The available measuring points make varied applications possible. Prior to ordering a device, please configure the application with DIGSI 5. Table "Functions and application templates" shows the functional scope of the device. Use the configurator to determine the necessary function points.

Application examples

The application templates of the SIPROTEC 7UT85 are also available for the SIPROTEC 7UT86.

In addition, the following templates are available:

Three-winding transformer basis

- Differential protection

Auto transformer with stabilizing winding

- Differential protection for the complete transformer (auto transformer winding + stabilizing winding)
- Ground fault differential protection (neutral point + maximum side current)

- Overload protection, backup protection for the downstream electrical power system
- Circuit-breaker failure protection

Three-winding transformer in breaker-and-a-half layout

- Differential protection
- Ground fault differential protection on the star side
- Ground current protection on the neutral side as backup protection for the electrical power system
- Overload protection
- Circuit-breaker failure protection
- Frequency and voltage protection on the neutral side

Figure 2.11/10 shows the template for the protection of a three-winding transformer in a breaker-and-a-half layout. You can recognize the 3 required function groups for the transformer side, the integration of the ground fault differential protection as well as the internal interconnection and selected functions. In addition, a voltage transformer is available on the upper-voltage side. Here, for example, voltage and frequency limits can be monitored. The required protection settings are made as required by the system.

SIPROTEC 5 Devices and Fields of Application

Transformer Differential Protection – SIPROTEC 7UT86

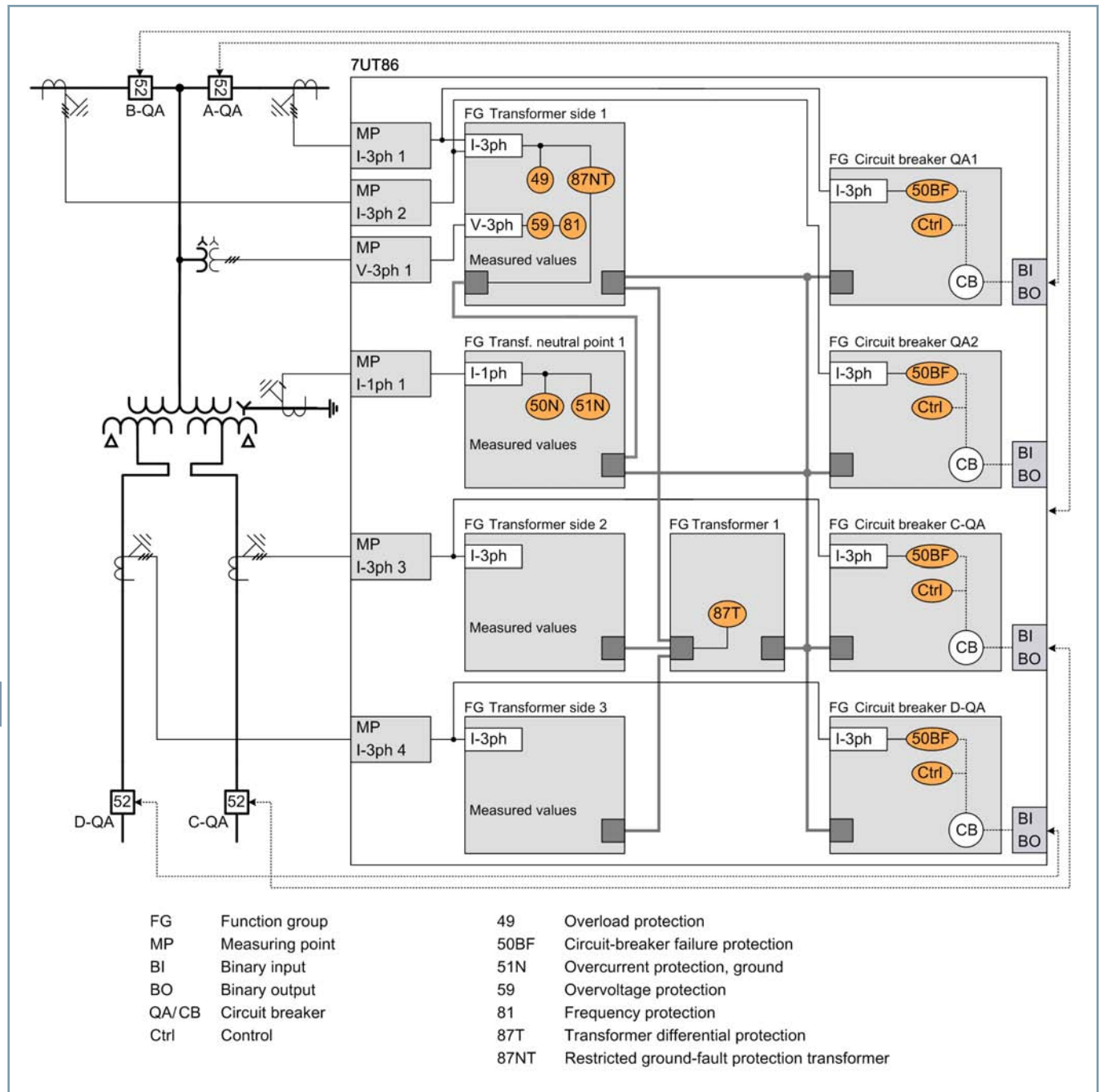

[dw_Kat-three-wind, 1, en_US]

Figure 2.11/10 Application example: Protection of a three-winding transformer in breaker-and-a-half layout

SIPROTEC 5 Devices and Fields of Application

Transformer Differential Protection – SIPROTEC 7UT86

Functions and application templates

ANSI	Functions	Abbr.	Available	Template												
				1	2	3	4	5	6	7	8	9	10			
	Hardware quantity structure expandable	I/O	■													
21/21N	Distance protection	Z<, V< /I>/∠(V,I)	■			■										
21T	Impedance protection for transformers	Z<	■													
87L	Line differential protection for 2 line ends	ΔI	■													
24	Overexcitation protection	V/f	■													
25	Synchrocheck, synchronizing function	Sync	■													
27	Undervoltage protection: "3-phase" or "pos.seq. V1" or "universal Vx"	V<	■													■
32, 37	Power protection active/reactive power	P<>, Q<>	■													
32R	Reverse power protection	- P<	■													
37	Undercurrent	I<	■													
38	Temperature Supervision	θ>	■													
46	Negative sequence overcurrent protection	I2>	■													■
46	Unbalanced-load protection (thermal)	I2² t>	■													
47	Overvoltage protection, negative-sequence system	V2>	■													
47	Overvoltage protection, negative-sequence- / positive-sequence system	V2/V1>	■													
49	Thermal overload protection	θ, I²t	■		■	■	■	■	■	■		■	■	■	■	■
49H	Hot spot calculation	θh, I²t	■													
50/51 TD	Overcurrent protection, phases	I>	■		■	■	■	■	■	■	■	■	■	■	■	■
50N/ 51N TD	Overcurrent protection, ground	IN>	■									■				
50HS	High speed instantaneous overcurrent protection	I>>>	■													
	Instantaneous tripping at switch onto fault	SOTF	■													
50N/ 51N TD	Overcurrent protection, 1-phase	IN>	■		■	■	■						■			
50Ns/ 51Ns	Sensitive ground-current protection for systems with resonant or isolated neutral	INs>	■													
	Intermittent ground fault protection	lie>	■													
50BF	Circuit-breaker failure protection, 3-pole	CBFP	■		■	■	■	■				■	■	■	■	■
50RS	Circuit-breaker restrike protection	CBRS	■													
51V	Voltage dependent overcurrent protection	t=f(I,V)	■													
59, 59N	Overvoltage protection: "3-phase" or "zero seq. V0" or "pos.seq. V1" or "universal Vx"	V>	■		■	■		■						■	■	■
59	Overvoltage protection: "3-phase" or "pos.seq. V1" or "universal Vx"	V>	■													
67	Directional overcurrent protection, phases	I>, ∠(V,I)	■													
67N	Directional overcurrent protection for ground faults in grounded systems	IN>, ∠(V,I)	■													
67N	Directional overcurrent protection, ground	IN>, ∠(V,I)	■													■
67Ns	Dir. sensitive ground-fault detection for systems with resonant or isolated neutral incl. a) 3I0>, b) V0>, c) Cos-/SinPhi, d) Transient fct., e) Phi(V,I), f) admittance		■													
	Directional intermittent ground fault protection	lie dir>	■													
68	Power-swing blocking	ΔZ/Δt	■													
74TC	Trip circuit supervision	TCS	■	■	■	■	■	■	■	■	■	■	■	■	■	■
79	Automatic reclosing, 3-pole	AR	■													
81	Frequency protection: "f>" or "f<" or "df/dt"	f>,<; df/dt>,<	■		■	■		■								■
85/21	Teleprotection for distance protection		■													
85/27	Weak or no infeed: Echo and Tripping	WI	■													

SIPROTEC 5 Devices and Fields of Application

Transformer Differential Protection – SIPROTEC 7UT86

ANSI	Functions	Abbr.	Available	Template										
				1	2	3	4	5	6	7	8	9	10	
85/67N	Teleprotection for directional ground fault protection		■											
86	Lockout		■	■	■	■	■	■	■	■	■	■	■	
87T	Transformer differential protection	ΔI	■	■	■	■	■	■	■	■	■	■	■	
87T	Transformer differential protection for phase angle regulating transformer (single core)	ΔI	■											
87T	Transformer differential protection for special transformers	ΔI	■											
87T Node	Differential protection (Node protection for Auto-transformer)	ΔI Node	■					■						
87N T	Restricted ground-fault protection	ΔIN	■		■	■	■			■	■			
87M	Motor differential protection	ΔI	■											■
87G	Generator differential protection	ΔI	■											
	Option for line differential protection:charging-current compensation	ΔI	■											
87 STUB	STUB Differential protection (for one-and-half circuit-breaker applications)		■											
90V	Automatic voltage control for 2 winding transformer		■										■	
90V	Automatic voltage control for 3 winding transformer		■											
90V	Automatic voltage control for grid coupling transformer		■											
FL	Fault locator, single-ended measurement	FL-one	■											
PMU	Synchrophasor measurement (1 PMU can be used for max. 8 voltages and 8 currents)	PMU	■											
AFD	Arc-protection (only with plug-in module ARC-CD-3FO)		■											
	Measured values, standard		■	■	■	■	■	■	■	■	■	■	■	■
	Measured values, extended: Min, Max, Avg		■											
	Switching statistic counters		■										■	
	Circuit breaker wear monitoring	ΣIx, I²t, 2P	■											
	CFC (Standard, Control)		■	■	■	■	■	■	■	■	■	■	■	■
	CFC arithmetic		■											
	Switching sequences function		■											
	Inrush current detection		■		■	■	■	■	■	■	■	■	■	
	External trip initiation		■							■	■			
	Control		■	■	■	■	■	■	■	■	■	■	■	■
	Fault recording of analog and binary signals		■	■	■	■	■	■	■	■	■	■	■	■
	Monitoring and supervision		■	■	■	■	■	■	■	■	■	■	■	■
	Protection interface, serial		■											
	Circuit Breaker		■	■	■	■	■	■	■	■	■	■	■	■
	Disconnecter		■											
	Transformer Side 7UT86		■											
Function-points class:				0	50	150	30	30	0	30	30	175	50	
The configuration and function points for your application can be ascertained in the SIPROTEC 5 order configurator under: www.siemens.com/siprotec														

Table 2.11/3 SIPROTEC 7UT86 - Functions and application templates

- 1 Three winding transformer basic (87T)
- 2 Three winding transformer 1,5CB (87T, 50BF, 87N)
- 3 Three winding transformer (87T, 50BF, 87N, 21)
- 4 Autotransformer (87T, 87N, 50BF)

SIPROTEC 5 Devices and Fields of Application

Transformer Differential Protection – SIPROTEC 7UT86

- 5 Autotransformer 1,5CB (two 87T, 50BF, 59, 27, 81)
- 6 Two winding transformer basic (87T)
- 7 Two winding transformer (87T, 50BF, 87N)
- 8 Two winding transformer 1,5CB (87T, 50BF, 87N)
- 9 Two winding transformer (87T, 50BF, 87N, 90V)
- 10 Motor DIFF (87M, 50BF, 27, 81, 46, 49)